

SEA&SEA

03114
03115

UNDERWATER STROBE



YS-D1

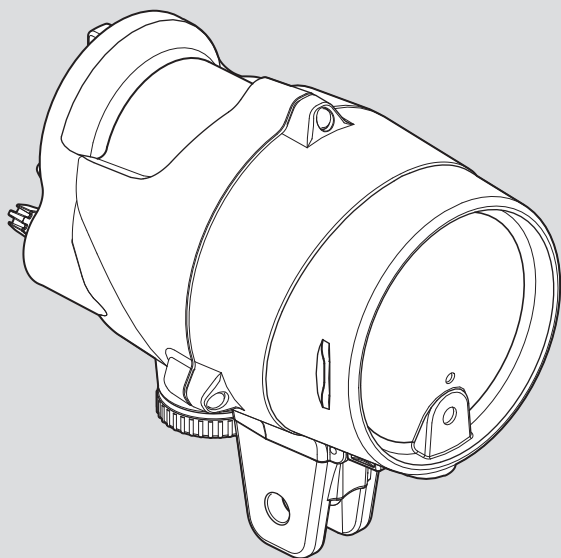

日本語

English

取扱説明書
Instruction Manual

Introduction

Thank you for purchasing SEA&SEA products. Please read this instruction manual carefully prior to using your underwater strobe. Only with a thorough understanding of this manual's content will you be able to use the strobe correctly. After reading the manual, please be sure to keep it in a place where you can easily come back to it at any time.

Note:



Products bearing this sticker are those that have passed SEA&SEA's criteria-based inspection for pressure resistance.



This device complies with Part 15 of the FCC Rules. Operation is subject to the following two conditions: (1) this device may not cause harmful interference, (2) this device must accept any interference received, including interference that cause undesired operation.



The product conforms to WEEE standards. This symbol indicates separate collection of waste electrical and electronic equipment in the EU countries. Please do not throw the equipment into the domestic refuse. Please contact your local authorities for recycling program information.

The appearance of color evenness or weld lines on the external body of the product is normal and will not affect its performance.

Contents

Safety Precautions	E-3
Safety Precautions for Use of Battery	E-6
Precautions on Handling the O-ring	E-8
Accessories	E-10
Identification of Parts	E-11
Operation	E-12
Ready/TTL lamp	E-13
YS Mount Strobe Adaptor/Ball Mount Strobe Adaptor.....	E-14
Preparation for Setting Up	E-16
Installing the Batteries	E-17
Connecting the Strobe	E-19
With the Sync Cord	E-19
With the Fiber-optic Cable	E-21
Taking Photographs	E-23
Using the Sync Cord	E-23
Using the Fiber-optic Cable	E-24
Using the Diffuser	E-26
Maintenance and Storage	E-28
Troubleshooting	E-29
Specification	E-31

Safety Precautions

For safe handling of the product, please read the following precautions carefully before use.

Failure to heed the precautions listed below could result in serious consequences. To prevent injury or damage to yourself and/or others, please observe the precautions as they contain highly important information related to personal and product safety.

 **DANGER** Situations that involve a high risk of severe injury or death.

 **WARNING** Situations that could result in severe injury or death.

 **CAUTION** Situations that could result in property damage or personal injury.

DANGER

- Never attempt to disassemble, repair or alter the product yourself to prevent significant electrical hazard due to the high-voltage circuitry in the product. Do not heat the product or put it into a fire, this could result in explosion or fire. Unauthorized disassembling and/or modification could result in malfunction or flooding, and avoid product warranty. Take the product to a SEA&SEA authorized service center for repair or inspection.

WARNING

- Use only batteries approved for use in this product. Do not mix old and new batteries of different types.
- Remove batteries before transport or storage, or when you are not going to use the product for an extended period of time, to prevent unexpected activation.
- Pay particular attention to opening the battery cap to avoid injury. Heat from the batteries may cause pressure buildup inside the battery compartment, and could result in cap explosion with unexpected force.
- Avoid water or foreign objects inside the product. Discontinue use and turn it off immediately should you notice flooding or leakage. Continuous use could result in complete damage to the product.
- Do not handle batteries wet hands to prevent shock hazards.
- Do not use the product in the presence of flammable gas, as this could result in explosion or fire.
- Do not fire the strobe/light with the reflector touching a person or object to prevent heat generation. Touching the reflector immediately after firing could result in burns.

- Do not fire the strobe or illuminate the light towards a driver of a vehicle to avoid causing accidents.
- Do not operate the product while driving a vehicle. Inattention could result in accidents.
- For use on land, do not operate the product at precarious foothold. It may cause falling, injury or product damage.
- Do not leave the product on a slope or an unstable surface. It may be broken after falling or injure someone below it.
- Keep out of reach of children to prevent accidental ingestion. If swallowed, seek medical advice immediately.

CAUTION

- Read the instruction manual and observe proper precautions before use of this product.
- This product has been designed and manufactured for use at a water depth within 100m / 330ft. Please note that diving to a depth in excess of 100m / 330ft may cause damage to the product or may lead to water leakage.
- Should you notice smoke or an unusual smell coming from the product, turn it off and remove the batteries immediately, taking care to avoid burns. Continued operation could result in injury. After removing the battery, take the product to a SEA&SEA authorized service center for inspection.
- Discontinue use and turn the product off immediately should you notice flooding or leakage.
- When the product is flooding, interior pressure may build up. Please be careful when opening the product as water may spurt out or the cap may open explosively and cause injuries.
- Do not open the battery cap in the vicinity of open flames.
- The product has been constructed with an airtight seal. When packing the product for airplane travel, do not seal-up the product to alleviate pressure build up due to atmospheric changes.
- Do not open the product in a wet or sandy environment. Protect the interior from moisture and debris in order to prevent malfunction or flooding.
- Keep away from strong magnetic fields. Do not use or store this product in the vicinity of equipment that generates strong electro-magnetic radiation or magnetic fields. Strong static charges or the magnetic fields could cause malfunction, or affect the product's internal circuitry.
- Before using the product in an airplane or a hospital, check if it is allowed. Electromagnetic waves emitted by the product may interfere with the measuring instruments or medical equipment.
- Do not cover or wrap the product with a cloth. This could result in deformation of the product or in fire.
- Using the strobe close to your subject's eyes could cause temporary visual impairment. Particular care should be observed if photographing infants, the strobe should be no less than one meter (3 feet) from the subject.

- Be careful when touching the product immediately after firing repeatedly or lighting for a long time. The product may get hot enough to burn you.
- Avoid strong shocks / impacts or excess stress to prevent malfunction, damage or breakdown. Make sure that the product has been securely mounted to other products in order to prevent injury, fall or missing.
- Do not carry the camera or housing by holding the accessories such as arm, cable, strobe, etc. Heavy components may fall and cause damage or injury.
- Do not rest heavy weight on the product. It might deform the outer casing, damage internal parts, make the waterproofing fail, or result in fire or electric shock.
- Rinse the product with fresh water, after underwater use. Ensure that the product is waterproofed before rinsing. Refer to [Maintenance and Storage] for details.
- Make sure that the connectors have been secured with the connector caps before rinsing the product with fresh water, after removal from other products.
- Never use chemicals, cosmetics, any petroleum solvents such as paint thinner, or neutral detergent on the product. They may deform and damage the product.
- Do not leave the product in places with hot temperatures such as inside of a car or in a car trunk in summer. The heat may deform plastic parts of the product, damaging internal parts and resulting in potential fire or electric shock. If the product is sealed tight in hot conditions, heated air expanding inside the product may deform the casing and ruin the waterproofing.
- Do not store the product in wet or high humidity place, to avoid mold, rust, corrosion or malfunction.
- Do not store the product with naphthalene or camphor mothballs, or in locations such as a laboratory where chemicals are used. This environment can cause mold, rust, corrosion or malfunction.
- If you do not use the product for an extended period of time, periodic maintenance will keep internal electronic parts from deterioration. Once a month, install batteries and fire a test flash / light on. Operate all other switches as you would in normal operation. Turn the power off, then remove batteries while the Ready/TTL lamp (red/green) is on for the strobe.
- SEA&SEA SUNPAK Co., Ltd. assumes no liability for compensation of loss of captured images or expenses caused by loss of images, even if you are unable to shoot due to a product defect or malfunction.
- SEA&SEA SUNPAK Co., Ltd. will not be responsible for the replacement or compensation for cameras, lenses or those accessories damaged due to your invalid operation.
- Carefully observe the O-ring maintenance manual for the handling of O-rings before use.
- SEA&SEA SUNPAK Co., Ltd. assumes no liability for errors or discrepancies in this manual.
- Specifications and appearance are subject to change without notice.
- The silicon grease included in the product package is inedible.

Safety Precautions for Use of Battery

DANGER

- Never expose the battery to flame or fire, or to excessive heat.
- Never attempt to disassemble, alter or directly solder the battery. There are no user-serviceable parts. Tampering with battery may expose you to dangerous voltage, battery acid, or electrical shock.
- Never short-circuit the terminals of a battery, as it could result in battery leakage, heat generation, fire, or explosion. Avoid contact with all metal objects during transporting and storage.
- When recharging batteries such as nickel metal-hydride or lithium-ion batteries, use a charger designed specifically for them and follow the recharging instructions. Recharging in an inappropriate charger may cause battery leakage, overheating, and explosion.
- Move leaking batteries away from fire or open flames immediately. The leaked fluid and its vapor are combustible.
- If the battery leakage contacts your skin or clothing, flush the affected area repeatedly with clean water. It may irritate your skin.
Should it get into your eyes, immediately rinse them with plenty of water, avoid rubbing and seek medical advice.
- Never attempt to insert the battery upside down or backward, as it could result in battery leakage or exposure. Always confirm the direction of plus and minus before installation.
- Never connect a battery directly to a plug outlet or car cigarette lighter.

WARNING

- Keep dry. The battery is not waterproof, and may malfunction if immersed in water or exposed to high levels of humidity. Rusting of the internal mechanism can cause irreparable damage.
- Do not remove and/or damage the case of a battery. It may cause battery leakage, overheating or explosion.
- Do not charge a rechargeable battery beyond the specified charging time, it may cause battery leakage, fire hazard or explosion.
- Never use batteries should you notice any changes such as leakage, discoloration or deformation. When you notice the situation as abnormal, discontinue use immediately and take the product to a SEA&SEA authorized service center for inspection.
- Keep out of reach of children to prevent accidental ingestion. If swallowed, seek medical advice immediately.
- Do not leave or use batteries in an extreme hot environment. This may cause battery leakage, overheating or battery performance deterioration.

 **CAUTION**

- Avoid strong shocks / impacts or excess stress to batteries.
- For handling and recharging of a battery, refer to the instruction manual of the battery/dedicated charger.
- Do not use or discharge the battery at ambient temperatures below 0°C (32°F) or above 50°C (122°F).
- During recharging, the temperature should be in the vicinity from 0°C to 40°C (32°F to 104° F).
- Always recharge the rechargeable battery before use after an extended time of storage.
- Do not recharge battery in a cold environment below 0°C (32°F). Severe cold may cause battery leakage, deterioration in performance, or shortened life.
- Dirt on the battery terminals can prevent the product from functioning. Should the battery terminals become dirty, wipe them with a clean, dry cloth before use.
- Turn the equipment off after use. Remove batteries from the equipment when not in use. Store in dry area with temperatures ranging from 0°C to 30°C (32°F to 86°F).
- Used rechargeable batteries are valuable resource. Please recycle used rechargeable batteries in accordance with local regulations.

Precautions on Handling the O-ring

This product is kept watertight by the O-ring. To keep the O-ring functioning properly, please observe the following. Improper handling of the O-ring could cause flooding.

CAUTION

- SEA&SEA products use blue O-rings. These O-rings are impregnated with silicone oil through a special process. The lubricating effect of the O-ring lasts as long as the silicone oil is gradually seeping out from within.
- For the maintenance of these blue O-rings, make sure to use genuine SEA&SEA silicone grease (O-ring grease for use with the blue O-rings that comes in tubes with blue lettering and blue caps). If you use silicone grease from other companies or SEA&SEA's own silicone grease that comes in tubes with black lettering and black caps, the grease you apply will be sucked into the blue O-rings due to their special characteristics, which will result in insufficient grease. If this happens even once, the O-ring will not revert to its normal state and must be replaced.
- If the grease is insufficient, the O-ring will not slide, and it will become harder to open and close the waterproof parts. Because of this, it could become impossible to open or close the housing or it could cause flooding, so please refrain from using the housing with insufficient grease.

Are there any scratches or cracks in the O-ring?

Check the O-ring to make sure there are no scratches or cracks. If there are, replace the O-ring with a new one immediately. When handling the O-ring, do not use pointed metal objects, which could damage the O-ring. Use of the included O-ring remover is recommended.

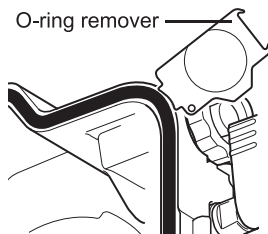

Be careful about dust, sand, and hair

Check the O-ring to make sure that there is no dust, sand, or hair on the O-ring, in the O-ring's grooves, or on the O-ring's contact surfaces. If any of these things are attached, remove them completely. If used as is, these things could cause flooding.

Coat with silicone grease

Silicone grease protects the O-ring from chafing. After checking the O-ring to make sure that there are no scratches, dust, or debris, apply a light coating of silicone grease to the entire O-ring with your finger. Applying too much grease will make it easier for dust and debris to adhere to the O-ring, and could cause flooding.

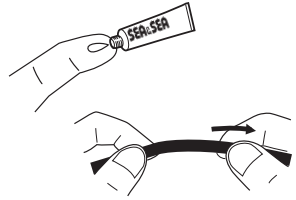

Do not twist the O-ring

When fitting the O-ring into the O-ring groove, insert it straight into the groove; do not bend or twist it.

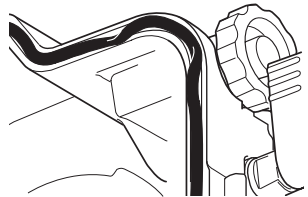

Remove the O-ring for inspection before each use

In principle, the O-ring should be removed before each use so that the O-ring, O-ring groove, and O-ring contact surfaces can be checked. This is because you cannot find any sand or debris that may have gotten into the O-ring groove if the O-ring is not removed. For routine maintenance prior to each use, it is advisable to make sure to remove the O-ring.

Be careful about how you store O-rings

When storing spare O-rings or O-rings that you have removed from the housing, keep them in a cool place out of direct sunlight. Also, when storing O-rings, do not place heavy objects on them or twist them.

O-rings last for one year

Although it depends on how well they are maintained, how often they are used, and how they are stored, O-rings generally last for one year. It is advisable to inspect them before use, and replace them early.

Accessories

Before using this model, check to make sure that all accessories are present.

YS-D1

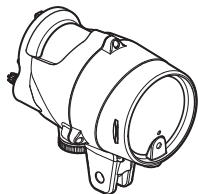

Diffuser-100

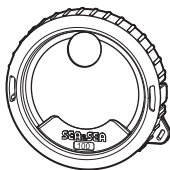

**YS Mount Strobe Adaptor
(mounted on the YS-D1)**

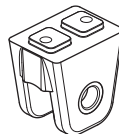

Silicone Grease



Diffuser-120



Ball Mount Strobe Adaptor

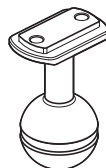

Fixing Bolt

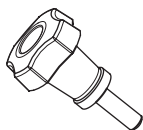

M4 Hexagon Wrench



Spare cap bolt (×1)



- Diffuser Strap (×2)
- O-ring Maintenance Manual
- YS-D1 Instruction Manual (this manual)

Identification of Parts

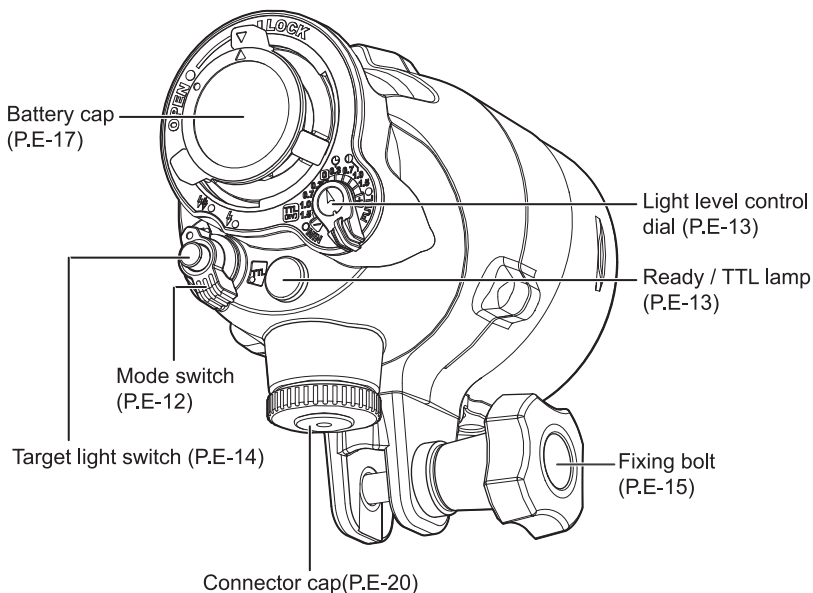
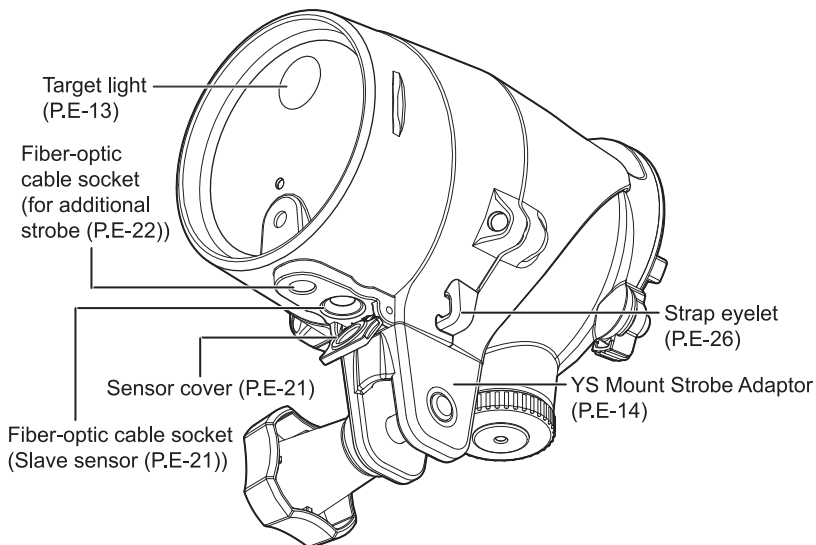

Operation

Mode Switch

OFF Turns the power off. Set the mode switch to [OFF] when you are not using the strobe.



Set the mode switch to this position if setting the light amount to Manual.

- When connecting using a fiber-optic cable, set the mode switch to this position for digital cameras with pre-flash modes.



Set the mode switch to this position if setting the light amount to Manual.

- When connecting using a fiber-optic cable, set the mode switch to this position for digital cameras without pre-flash modes.

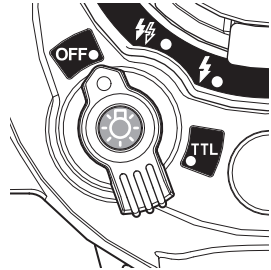

TTL Set the mode switch to this position when shooting with TTL flash output

- When a fiber-optic cable is connected, DS-TTL II mode is activated. (You can switch to Slave-TTL mode by pressing and holding down the target light switch for 3 seconds.)

⇒ “DS-TTL II mode photography” (P.E-24)





Pre-flash

With some types of digital cameras, the light amount is adjusted with the first and the image is taken with the second flash (main flash). The first flash for adjusting the light amount is called a pre-flash.

⚠ CAUTION

- The number of times a digital camera's built-in flash will fire differs among models. Depending on the number of pre-flashes mode switch settings can differ, so check settings before shooting by conducting test flashes.
 - ⇒ “To check the mode switch” (P.E-23)
- [⚡] and [⚡/] have the completely same performance when the strobe is connected with a sync cord.
- When 30 minutes has passed from turning on the power, or last emission of the strobe, the power will turn off automatically (auto power-off). When turning on the power again, set the mode switch to [OFF] before setting the desired mode.
- In TTL mode, mode statuses set at the time of power off are saved, and therefore, if the power is turned off while the unit is set to Slave-TTL mode, the unit will start up in Slave-TTL mode at next power up.

Light level control dial

Light amount can be adjusted in 11 increments (GN: 1 / 1.4 / 2 / 2.8 / 4 / 5.6 / 8 / 11 / 16 / 22 / 32) when the mode switch is set to [] or []. Marks can be used to verify 1/4 () or 1/2 () of full flash.

If the mode switch is set to [TTL] and a fiber-optic cable is connected (in DS-TTL II mode), EV compensation is performed.

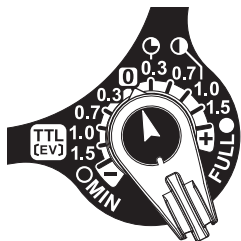

CAUTION

- When the strobe is connected to a SLR housing with a sync cord and the mode switch is set to [TTL], normal TTL mode is activated and you cannot adjust the EV compensation.

Target light switch

The target light turns on when you push the target light switch. The target light turns off when you push the switch once again.

The target light turns off when the strobe fires, and lights up again when the strobe is ready to fire (when the Ready lamp illuminates in red).

Press the button and hold it down for 3 seconds in TTL mode to switch to Slave-TTL mode (the lamp illuminates blue).



CAUTION

- The target light continues to be illuminated until pushing the switch, setting the mode switch to [OFF], or until the power turns off automatically (auto power-off).
- The target light will flicker when the batteries get low, this is not a malfunction.
- Press and hold down the target light switch for one second to turn it [ON] or [OFF] in TTL mode.

Ready/TTL lamp

Ready Illuminates in red when the strobe is ready to fire.

TTL After shooting with TTL automatic light control is completed, the TTL lamp will illuminate in green for approximately 2 seconds.

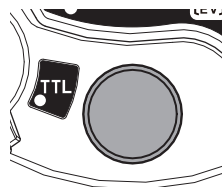

CAUTION

- The power lamp flashes red/green when the remaining battery power is low or an internal protective circuit is activated if the product begins emitting light continuously. Replace the battery with new or turn off the power, and leave the product in a cool place when the power lamp starts flashing as described.

YS Mount Strobe Adaptor / Ball Mount Strobe Adaptor

A YS Mount Strobe Adaptor is included with this product as standard equipment. You can change the orientation for the inserted fixing bolt by changing the orientation for attachment of the YS Mount Strobe Adaptor. By replacing it with the included Ball Mount Strobe Adaptor, you can select a method for attachment to a housing that matches the shooting conditions.

How to detach a YS Mount Strobe Adaptor

- 1 Remove the two cap bolts used to secure the YS Mount Strobe Adaptor using the included hexagon wrench turned counter-clockwise

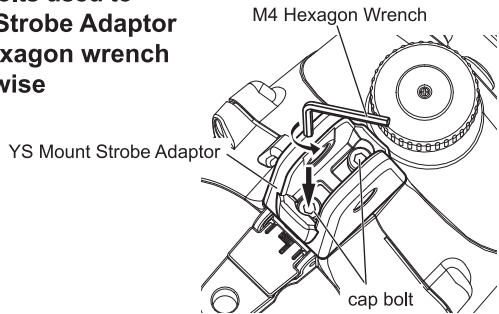

How to attach a Ball Mount Strobe Adaptor

- 1 Attach the Ball Mount Strobe Adaptor to the camera and lightly secure it using the two cap bolts turned clockwise by hand.

- Use the cap bolts screwed into the YS Mount Strobe Adaptor.

- 2 Use the included hexagon wrench to firmly tighten the cap bolts and secure the adaptor to the unit.

- Use the short end (as shown in the diagram at right) of the hexagon wrench to tighten cap bolts.
- Do not apply excessive force where tightening up the cap bolt.

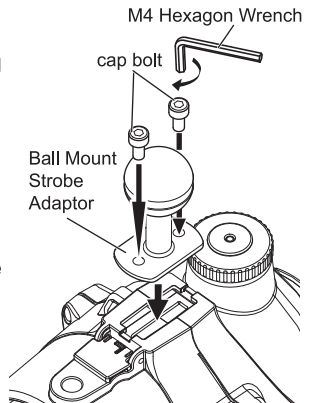

Fixing Bolt

If attaching the unit to an arm or other part, insert the fixing bolt from the side of the YS Mount Strobe Adaptor which does not have a nut inserted and tighten to secure.

《 Correct 》

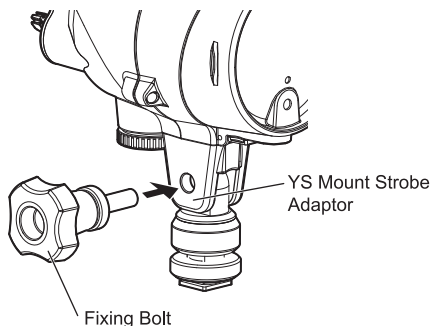

《 Wrong 》

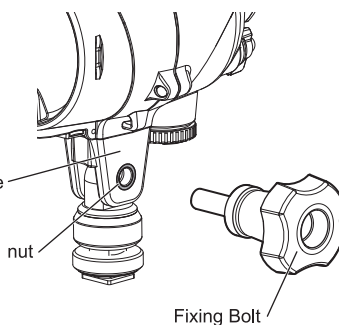

Attaching from the opposite direction

At factory shipment, the fixing bolt is inserted to be attached from the left side as seen from the front of the housing; however, by changing the direction of attachment of the YS Mount Strobe Adaptor, you can also attach it from the right side.

- Be sure to change the direction of attachment for the YS Mount Strobe Adaptor. Failure to do so may cause the YS Mount Strobe Adaptor or other parts to become damaged.
- When attaching the YS Mount Strobe Adaptor, always refer to [YS Mount Strobe Adaptor / Ball Mount Strobe Adaptor] (P.E-14) for details.

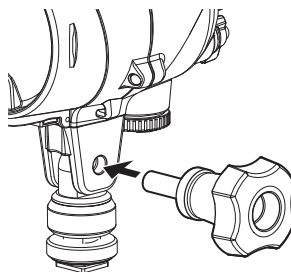

⚠ CAUTION

- Please be careful when attaching the YS Mount Strobe Adaptor as inserting the fixing bolt from the side that does not have a nut inserted may lead to it or other parts becoming damaged.
- Do not tighten the fixing bolt up on the product unless it is being attached to an arm.
- Remove the fixing bolt from the product when storing.

Preparation for Setting Up

Maintaining the O-ring

This product is kept watertight by the O-ring. To keep the O-ring functioning properly, please observe the following before setting up.

- Make sure to remove the O-ring when maintaining.
- For detailed O-ring maintenance methods, please see the O-ring maintenance manual.

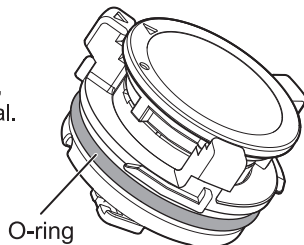

CAUTION

- Make sure to fit/install the O-ring into the groove properly after maintenance.

Installing the Batteries

This model can be powered by the following batteries. Use four of each type.

AA alkaline battery, AA Ni-MH battery

1 Make sure that the mode switch is in the OFF position

2 Turn ▽ mark counterclockwise to the OPEN ○ position

3 Pull the battery cap straight out

- When open a battery cap, always pull battery caps sideways.

4 Insert four batteries aligned to the + and - marks

- Take care to insert the batteries in the correct direction.

5 Verify that the ○ mark on the battery cap is lined up with the ▽ mark

6 Align the battery cap with the OPEN ○ position, and insert the battery cap into the strobe

- Check the O-ring to make sure there are no scratches or debris.

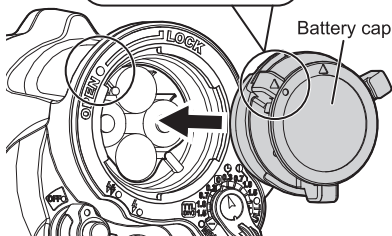
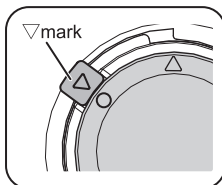
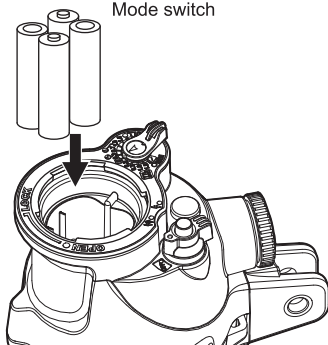
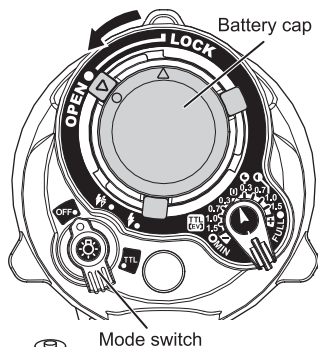

7 Turn ▽ mark clockwise to the LOCK position

- Turn until you hear the sound of it clicking into place.

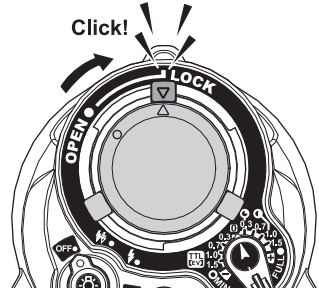

⚠ CAUTION





- Replace the batteries when it takes 30 seconds or more until the Ready/TTL lamp illuminates in red after firing with FULL output.
- When installing or removing batteries, thoroughly wipe water off the strobe and dry your hands. Pay particular attention not to allow water from your hair or wetsuit to drip into the battery compartment. This is in order to prevent an electrical hazard, mold, malfunction or flooding.
- Never mix old and new batteries or batteries of different types.
- Always replace all batteries with new batteries at the same time.

Connecting the Strobe

Setting and cords used to connect to this model can vary depending on the camera/housing model.

The various connection methods using different cords are described here. Refer to “Taking Photographs” on page E-23 for details on taking photographs while connected using different cords.

Strobe Setting Guide

Connection cord		Fiber-optic cable		Sync cord
Camera		with pre-flash(es)	Without pre-flash	Digital camera
Manual	Mode switch			 / 
	Light level control dial	11-step	11-step	11-step
TTL	Mode switch	TTL	—	TTL *1
	Light level control dial	±4-step	—	—

*1 The SEA&SEA YS Converter (optional) is required. For light level control while a YS Converter is connected, adjust the levels on the YS Converter side.

CAUTION

- If a sync cord is connected to the unit, the automatic recognition function will be activated and fiber-optic connection will be disabled even if a fiber optic cable is connected.

Connecting with the Sync Cord

When you want to use this strobe with a SLR housing which has a strobe/converter bulkhead, connect the strobe to the housing with a sync cord (optional). Some digital SLR housings require a SEA&SEA converter (optional) for TTL photography. Refer to your digital SLR housing instruction manual for details.

1 Remove the connector cap from the sync cord, and check the O-ring (strobe/camera or housing)

- Check the O-ring to make sure there are no scratches or debris, and apply a light coating of the included silicon grease.

2 Remove the strobe's connector cap

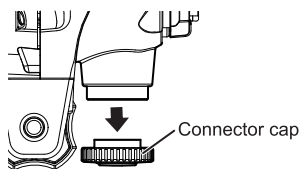

- 3** Align the convex part on the strobe's connector with the notch of the sync cord's connector, and then push it straight in

- 4** Align ① with the screws of the strobe, and then rotate it until it stops

- Tighten it securely.
- When removing the sync cord, loosen ① and while holding the base of the sync cord's connector, pull the sync cord straight out.
- Do not pull the cord.

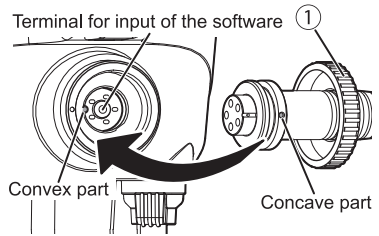

- 5** Remove the housing's bulkhead connector cap

- 6** Align the round mark on the sync cord (or the notch of the tip) and the round mark on the strobe bulkhead (or the convex part on the inside), and then push it straight in

- 7** Align the B part of the sync cord with the screws of the strobe bulkhead, and then rotate it until it stops

- 8** Rotate the C part of the sync cord until it stops

- Tighten it securely.
- When removing the sync cord, loosen C first, then B, and then pull the sync cord straight out holding onto A.
- Do not pull on the cord part.

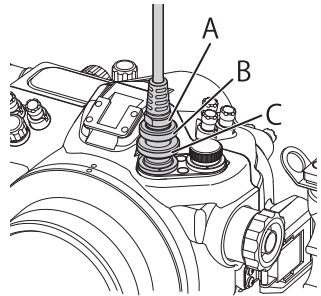

⚠ CAUTION

- Do not touch the terminal for input of the software with fingers. Do not apply silicone grease to the connector's contact pins. If contaminated accidentally, clean the pins by a cotton swab moistened with alcohol.
- Whenever a sync cord is not connected, protect the connectors with the connector caps.
- Before rinsing a detached sync cord, be sure to put the connector caps on the exposed ends.
- Refer to the sync cord instruction manual before use.

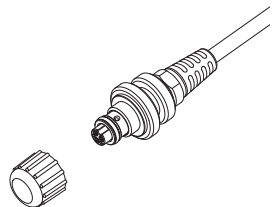

Connecting with the Fiber-optic Cable

Connect this product with the fiber-optic cable (option) when it is triggered by sensing the light from the camera's built-in flash. Using a built-in slave sensor, this strobe is triggered by sensing the light from a digital camera's built-in flash. If the fiber-optic cable is not used, DS-TTL II modulation cannot be obtained unless a fiber-optic cable is used.

⚠ CAUTION

- Some housings are not compatible with fiber-optic cable.
- Be sure to turn off power to the strobe before proceeding.

1 Open the sensor cover

- After using, manually move the cover and wash thoroughly with pure water.

➡ "Maintenance and Storage" (P.E-28)

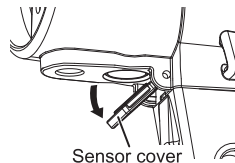

2 Insert the fiber-optic cable's connector into the fiber-optic cable socket (slave sensor) of the strobe until it stops

- When inserting the fiber-optic cable into the socket for additional strobe, the strobe will not fire correctly.

➡ "Fiber-optic cable socket (for additional strobe)" (P.E-22)

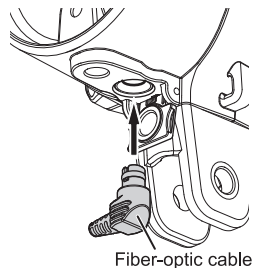

3 Connect the fiber-optic cable's connector to the socket in the housing

- When the fiber-optic cable cannot connect directly to a compact digital camera housing (no fiber-optic cable socket), attach the strobe mask (A: optional) to the flash window of the housing, and then connect the fiber-optic cable (B: optional).

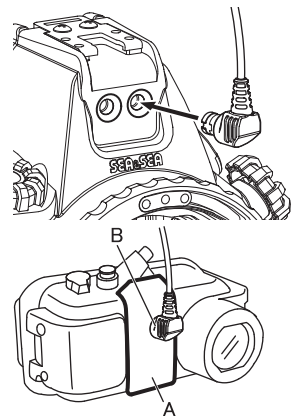

⚠ CAUTION

- When you shoot with a digital camera, set the built-in flash of the camera to the forced-flash mode. The strobe will not fire unless the built-in flash of the camera fires. Refer to the digital camera instruction manual for setting the forced-flash mode.
- Refer to the fiber-optic cable instruction manual before use.
- When using this model together with the SEA&SEA DX-1G/DX-2G set, please attach the fiber-optic cable adapter (included in the DX-1G/DX-2G) to the housing, and then use a fiber-optic cable.
- Refer to the housing instruction manual before use.

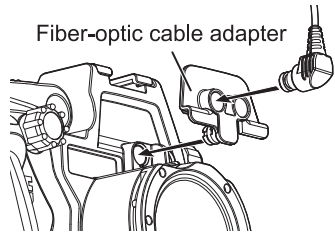
**Fiber-optic cable socket (for additional strobe)**

The fiber-optic cable socket (for additional strobe) is not a slave sensor. When using this strobe as a main strobe etc., another strobe can be added using a fiber-optic cable.

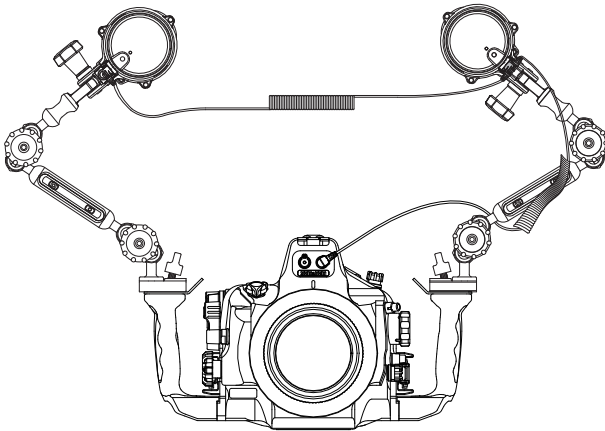

Taking Photographs



CAUTION

- If the full flash has been activated 10 times in a row, allow the product to rest for 10 minutes before attempting to use it again.
- Do not attempt to activate the flash on the unit with the flash facing downward.
- Do not look directly into the flash on the unit.

Using the Sync Cord

Manual photography

Light amount of the strobe can be adjusted with the light level control dial.

- 1 Set the mode switch to [] or []
- 2 Adjust with the light level control dial
- 3 Take a photograph

TTL photography

Shooting with TTL flash output.

- 1 Set the mode switch to [TTL]
- 2 Take a photograph

CAUTION

- Requires a SEA&SEA YS converter. Refer to your digital SLR housing instruction manual for details.

TTL photography

Photography based on the camera's photometric data of the subject's brightness, which is used to regulate the light amount of the strobe so that the correct exposure is achieved. Even if the distance from the subject has changed, the light amount will be controlled automatically and you can easily obtain the correct exposure. After shooting with TTL automatic light control, the TTL lamp will illuminate in green for approximately 2 seconds. When automatic light control was not used, the TTL lamp remains red. If the correct exposure cannot be obtained in TTL shooting mode, switch to manual shooting mode.



Using the Fiber-optic Cable

When you shoot with a digital camera, set the built-in flash of the camera to the forced-flash mode. The strobe will not fire unless the built-in flash of the camera fires.

Manual photography

Light amount of the strobe can be adjusted with the light level control dial.

1 Set the mode switch to [] or []

- When shooting with a digital camera that pre-flashes, set to [].
- When shooting with a digital camera that does not pre-flash, set to [].

2 Adjust with the light level control dial

3 Take a photograph

To check the mode switch

You can check whether the settings of the mode switch are correct, by shooting the strobe with a digital camera. The number of times a digital camera's built-in flash will fire differs depending on the shooting mode. If you change the shooting mode of the camera, check the setting of the mode switch again for that mode.

1 Set the camera's built-in flash to the forced-flash mode, and mount the camera to the housing. Then connect the housing and this product together with a fiber-optic cable.

- Release the red-eye-reduction function.

2 Set the mode switch to [] and the light level control dial to [FULL], point the digital camera at the front of the strobe and shoot an image.

- The built-in flash of the camera must flash.

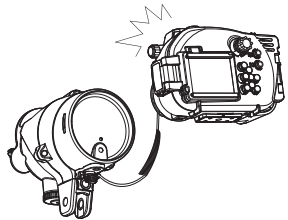

3 Check the image captured by the camera

- If you see a white flash in the strobe or an image that is completely white, then the strobe has fired and the setting is correct.
- If the image shows a dark reflection from the strobe, that means that it is not synchronized and the strobe didn't fire. Change the mode switch to [], try taking another picture, and then check the new picture.

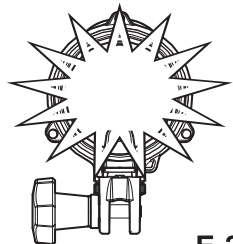

DS-TTL II mode photography

The DS-TTL II system included as a feature of the unit is a Slave-TTL system that is equipped with a compensation function. It is effective for use with a main strobe that has a pre-flash function (such as when there is a built-in TTL flash on the camera and another strobe connected to the camera by TTL). Please confirm a support model.

- Please refer to our website (<http://www.seaandsea.jp>) [Compatibility list for the strobe and digital cameras] for the support model of the camera.

- 1 Set the mode switch to [TTL]**
- 2 Adjust with the light level control dial**
- 3 Take a photograph**

CAUTION

- When you use this strobe connected to a SLR housing with a sync cord, DS-TTL II mode will NOT be activated.
- DS-TTL II mode is activated only when you are using a camera's built-in flash or other TTL strobe connected to the camera. Use this strobe as a sub-strobe of the main strobe. DS-TTL II can not be used if the main strobe (camera's built-in flash) is not equipped with the TTL function, or if the main strobe (camera's built-in flash) does not pre-flash.
- When you shoot with a digital camera, set the built-in flash of the camera to the forced-flash mode. The strobe will not fire unless the built-in flash of the camera fires.
- There may not be any effect obtained from compensation with the light level control dial depending on the shooting conditions and camera settings.

Slave-TTL mode photography

Slave-TTL mode detects the flash from the built-in flash on the camera and enables the strobe to flash.

- 1 Set the mode switch to [TTL]**
- 2 Press and hold down the target light button for 3 seconds**
 - Verify that the TTL lamp is illuminated blue.
- 3 Take a photograph**

CAUTION

- EV compensation cannot be performed in Slave-TTL mode.
- The TTL lamp will not illuminate green even if TTL auto adjustment has been completed.

Using the Diffuser

This product comes with two different diffusers (Diffuser-100, Diffuser-120). Please select between the two as needed to meet specific shooting applications. The two types of diffusers are attached in the same way.

- Diffuse-100 : GN:24(at full flash), Beam angle : 100°×100°
- Diffuse-120 : GN:20(at full flash), Beam angle : 120°×120°

Attaching

- 1 Attach the included diffuser strap to the strap eyelets on the diffuser and the strobe

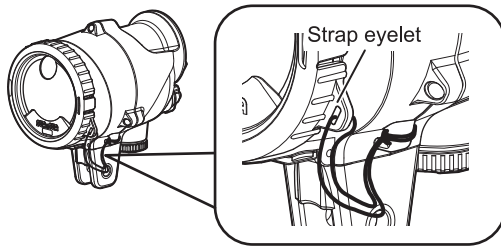

- 2 Line up the circular hole on the diffuser with the position on the target light, and push the tabs on the diffuser into the grooves (one on the left and one on the right) on the strobe until they snap into place.

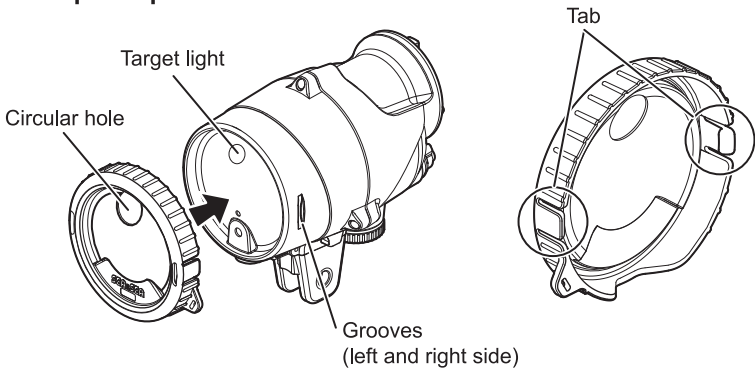

⚠ CAUTION

- Always make sure that the diffuser is properly attached before use. If not properly attached, it may fall off, get lost or become damaged.

Detaching

- 1 Turn the diffuser either to the left or to the right to release the tabs from the grooves on the strobe, and then pull it straight out to remove it.

- Do not attempt to turn the tabs while pushing them down.

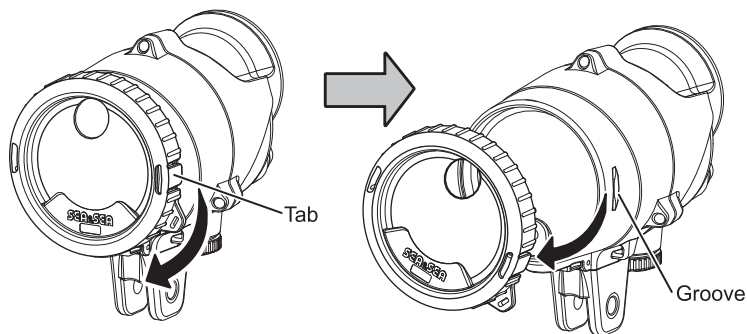

⚠ CAUTION

- Do not attempt to forcefully remove the diffuser while the tabs are still inserted into the grooves. Doing so may cause the diffuser to become damaged.

Maintenance and Storage

⚠ CAUTION

- Never use chemicals, cosmetics, any petroleum solvents such as paint thinner, or neutral detergent on the product. They may deform and damage the product.
- After each use in salt water, make sure the battery and connector caps are attached, then in a watertight condition soak it sufficiently in fresh water.

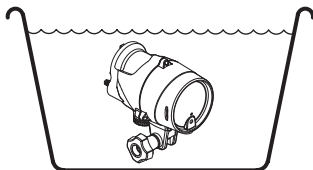

- Insufficient soaking causes damage by salt to the product. Salty residue may be left on the product where it will crystallize as it evaporates. Crystallized salt is hard to dissolve and difficult to be removed once formed, and it will result in water leakage.
- After rinsing, dry the product well with a soft dry cloth, then let the product dry in the shade, out of direct sunlight.
- Do not dry the product by heating (using a hair dryer, for example). Heating can deform and damage the product.
- If you will not use the product for an extended period of time, store it away from high temperatures, high humidity, direct sunlight, or extreme cold.
- Do not store the product with naphthalene or camphor mothballs, or in locations such as a laboratory where chemicals are used. This environment can cause mold, rust, corrosion or malfunction.
- Always remove batteries from the product after use.
- After using the product, maintain the O-rings before storing. Examine the O-rings before and after each dive. We recommend early exchange of the O-rings, at least once a year.
- Every two years we recommend a complete overhaul of O-rings regardless of the frequency in use, for the best performance of the product.
- If you do not use the product for an extended period of time, periodic maintenance will keep internal electronic parts from deterioration. Once a month, install batteries and fire a test flash. While the Ready/TTL lamp is red (strobe is ready to fire), set the mode switch to [OFF], then remove the batteries. In addition, operate all other switches as you would in normal operation.

Troubleshooting

Please confirm the following items. If conditions do not improve even after the following has been confirmed, please contact the World Customer Service Center or an authorized SEA&SEA dealer.

Ready/TTL lamp does not light up red

- Do you insert the batteries? (P.E-17)
- Do you insert the batteries the right way? (P.E-17)
- Did you make sure not to use any old batteries? (P.E-17)
- Has the battery cap been closed properly? (P.E-17)
- An internal protective circuit is activated if the product begins emitting light continuously. If this occurs, turn off the power supply, and put a product in a cool place for a while.
- An internal protective circuit is activated if the product is left in an area with high temperature. If this occurs, put the product in a cool place for a while. (P.E-5)
- If the product emits the FULL emission of light in more than 20 continuous bursts, an internal protective circuit will be activated to prevent the reflector in the strobe from overheating, and the strobe will be placed in standby mode (with the Ready/TTL lamp lights out) for at least 20 seconds. If this occurs, allow this product to cool naturally for at least ten minutes.

The target light does not turn on

- Was the target light button held down for the proper length of time? The target light may not turn on if the switch is held down for too short a time. Press and hold down the target light switch for one second. (P.E-13)

Using the Sync Cord

The strobe does not fire

- Is the sync cord connected properly? (P.E-19)
- Is there any rust on the metal pins of the connector? If there is any rust or damage found, please contact the World Customer Service Center or an authorized SEA&SEA dealer.

Using the Fiber-optic Cable

The strobe does not fire

- Is the fiber-optic cable connected properly? (P.E-21)
- Does the built-in flash/main strobe on the camera fire? (P.E-24)
- When there is a sync cord present, fiber-optic connection is disabled even if there is a fiber-optic cable connected to the unit. To use the strobe with the fiber-optic cable connection, remove the sync cord. (P.E-19)

The strobe emits light in manual photography mode, but images are dark

- Does the firing mode for the built-in flash/main strobe on the camera match the firing mode on the YS-D1? (P.E-24)
- Please refer to our website (<http://www.seaandsea.jp>) [Compatibility list for the strobe and digital cameras]. (P.E-25)

When photographs are taken in DS-TTL II mode, the captured images are too bright or too dark

- Is the fiber-optic cable connected properly? (P.E-21)
- Is the light level control dial in DS-TTL II mode set at +/- compensation? (P.E-13)
- Please refer to our website (<http://www.seaandsea.jp>) [Compatibility list for the strobe and digital cameras]. (P.E-25)
- There may not be any effect obtained from compensation with the light level control dial depending on the shooting conditions and camera settings.

The power will turn off automatically

- The auto power-off mode is turned on. When turning on the power again, set the mode switch to [OFF] before setting it to the desired mode. (P.E-12)

About LED indication

Indication	Point to be checked	Coping process	Page
Illuminates red	Fully charged	Ready to fire	P.E-13
Illuminates green for about 2 seconds	TTL automatic light control has been completed		P.E-13
Illuminates blue	Slave-TTL mode has been turned on	You can switch to TTL mode by pressing and holding down the target light switch for 3 seconds.	P.E-13
The red and green lamps flash alternately	There is no remaining battery power.	Replace the battery with a new one.	P.E-13
	The protective circuit is activated.	Turn off the power supply, and put a product in a cool place for a while.	P.E-29
blinks red	The protective circuit is activated.	Turn off the power supply, and put a product in a cool place for a while.	P.E-29
Illuminates green	The sync cord sensor operates.	If an error occurs while there is no synchronized cord connected, please contact the World Customer Service Center or an authorized SEA&SEA dealer.	P.E-29

Specifications

Controls	Mode switch (OFF/⚡ / ⚡ /TTL) Target light switch (ON/OFF) Light level control dial
Indicator	Ready lamp (Illuminates in red when the strobe is ready to fire.) TTL lamp (Illuminate in green for approx.2 sec after firing with DS-TTL II flash output.) Slave-TTL mode (Illuminates in blue when the strobe is ready to fire.)
Guide number	32 (at full flash) *ISO100/m 24 (with diffuser-100) , 20 (with diffuser-120)
Beam angle	80°×80° 100°×100° (with diffuser-100) 120°×120° (with diffuser-120)
Color temperature	5600°K (at full flash) *land 5250°K (with diffuser 100)
Battery life	Alkaline : Approx. 150 flashes Ni-MH(eneloop pro) : Approx. 250 flashes Ni-MH(eneloop) : Approx. 200 flashes
Recycle time	Alkaline : Approx. 2.8sec Ni-MH : Approx. 1.9sec
Batthey requirements	4×AA Alkaline, 4×AA Ni-MH
Operating temperature	0°C-40°C / 32°F-104°F
Construction	Polycarbonate, ABS resin
Depth rating	100m (330ft)
Dimensions(W×H×D)	87×135×111mm / 3.4×5.3×4.4inches
Weight	650g / 22.9oz (excl. batteries) * Attached a YS Mount
Weight underwater	5g / 0.17oz (incl. batteries) Strobe Adaptor and a fixing bolt to the Strobe.
Accessories	Diffuser-100, Diffuser-120, Diffuser strap (×2), O-ring maintenance manual, Sillicon grease, Ball Mount Strobe Adaptor, Fixing bolt, M4 Hexagon Wrench, Spare bolt cap (×1) Attached accessories to the product : YS Mount Strobe Adaptor

*The specifications and appearance are subject to change without notice.

*The performance values above may change depending on variables such as frequency of use, battery consumption, recharge level, and so on.

*The above specifications are based on normal room temperature (25°C/77°F).