

SEA&SEA

**UNDERWATER HOUSING for
Nikon D300**

MDX-D300

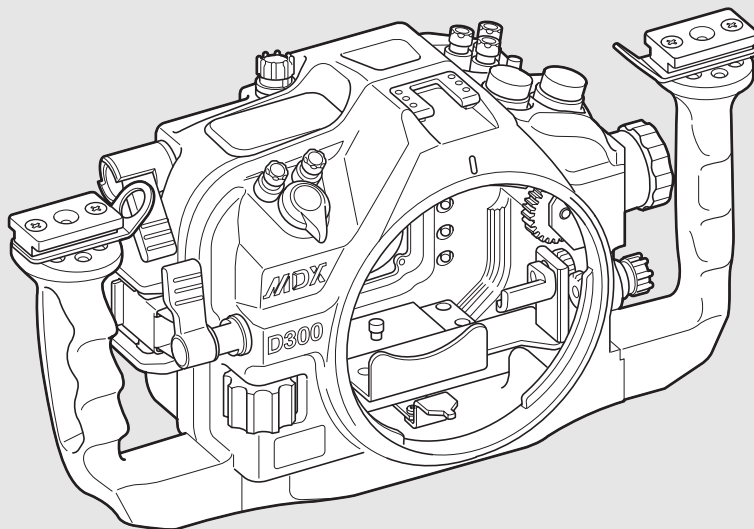

日本語

English

**取扱説明書
Instruction Manual**

Introduction

Thank you for purchasing SEA&SEA products. Please read this instruction manual carefully prior to using your underwater housing. Only with a thorough understanding of this manual's content will you be able to use the housing correctly. After reading the manual, please be sure to keep it in a place where you can easily come back to it at any time.

Note:

Pressure-resistance inspection sticker



Products bearing this sticker are those that have passed SEA&SEA's criteria-based inspection for pressure resistance.

Contents

Safety Precautions	E-2
Precautions on Handling the O-ring	E-4
Identification of Parts	E-6
Leak Sensor	E-7
Finder	E-8
Opening and Closing the Housing	E-9
Attaching and Detaching the Port	E-10
Mounting the Camera in the Housing	E-11
Connecting the Strobe	E-14
External Controls	E-15
Maintenance and Storage	E-18
Specifications	E-19

Safety Precautions

For safe handling of the product, please read the following precautions carefully before use.

Failure to heed the precautions listed below could result in serious consequences. To prevent injury or damage to yourself and/or others, please observe the precautions as they contain highly important information related to personal and product safety.

 **WARNING** Situations that could result in severe injury or death.

 **CAUTION** Situations that could result in property damage or personal injury.

WARNING

- Keep out of reach of children to prevent accidental ingestion. If swallowed, seek medical advice immediately.

CAUTION

- Carefully observe the instruction manual for the compatible camera for this product before use.
- Unauthorized disassembling and/or modification could result in malfunction or flooding, and void product warranty. Take the product to a SEA&SEA authorized service center for repair or inspection.
- Should you notice smoke or an unusual smell coming from the product, turn it off and remove the batteries immediately, taking care to avoid burns. Continued operation could result in injury. After removing the battery, take the product to a SEA&SEA authorized service center for inspection.
- Discontinue use and turn the product off immediately should you notice flooding or leakage.
- When the product is flooding, interior pressure may build up. Please be careful when opening the product as water may spurt out or the cap may open explosively and cause injuries.
- The product has been constructed with an airtight seal. When packing the product for airplane travel, do not seal-up the product to alleviate pressure build up due to atmospheric changes.
- Do not open the product in a wet or sandy environment. Protect the interior from moisture and debris in order to prevent malfunction or flooding.
- Avoid strong shocks/impacts or excess stress to prevent malfunction, damage or breakdown. Make sure that the product has been securely mounted to other products in order to prevent injury, fall or missing.
- Do not rest heavy weight on the product. It might deform the outer casing, damage internal parts, make the waterproofing fail, or result in fire or electric shock.
- Please note that some marks may be left on the camera scraping against the dials or gears of the housing.
- Handle the product carefully so as not to scratch the front port, the lens, the flash window or the finder.

Safety Precautions

- Always dry the front port, the lens, the flash window or the finder using a soft cloth to prevent stain or salt residue from marring the glass surface.
- Rinse the product with fresh water, after underwater use. Ensure that the product is waterproofed before rinsing. Refer to [Maintenance and Storage] (P.E-18) for details.
- Make sure that the connectors have been secured with the connector caps before rinsing the product with fresh water, after removal from other products.
- Never use chemicals, cosmetics, any petroleum solvents such as paint thinner, or neutral detergent on the product. They may deform and damage the product.
- Do not leave the product in places with hot temperatures such as inside of a car or in a car trunk in summer. The heat may deform plastic parts of the product, damaging internal parts and resulting in potential fire or electric shock. If the product is sealed tight in hot conditions, heated air expanding inside the product may deform the casing and ruin the waterproofing.
- Do not store the product in wet or high humidity place, to avoid mold, rust, corrosion or malfunction.
- Do not store the product with naphthalene or camphor mothballs, or in locations such as a laboratory where chemicals are used. This environment can cause mold, rust, corrosion or malfunction.
- SEA&SEA SUNPAK Co., Ltd. assumes no liability for compensation of loss of captured images or expenses caused by loss of images, even if you are unable to shoot due to a product defect or malfunction.
- SEA&SEA SUNPAK Co., Ltd. will not be responsible for the replacement or compensation for cameras, lenses or those accessories damaged due to your invalid operation.
- SEA&SEA SUNPAK Co., Ltd. assumes no liability for errors or discrepancies in this manual.
- Carefully observe the O-ring maintenance manual for the handling of O-rings before use.

Precautions on Handling the O-ring

This model is kept watertight by the O-ring. To keep the O-ring functioning properly, please observe the following. Improper handling of the O-ring could cause flooding.

CAUTION

- SEA&SEA products use blue O-rings. These O-rings are impregnated with silicone oil through a special process. The lubricating effect of the O-ring lasts as long as the silicone oil is gradually seeping out from within.
- For the maintenance of these blue O-rings, make sure to use genuine SEA&SEA silicone grease (O-ring grease for use with the blue O-rings that comes in tubes with blue lettering and blue caps). If you use silicone grease from other companies or SEA&SEA's own silicone grease that comes in tubes with black lettering and black caps, the grease you apply will be sucked into the blue O-rings due to their special characteristics, which will result in insufficient grease. If this happens even once, the O-ring will not revert to its normal state and must be replaced.
- If the grease is insufficient, the O-ring will not slide, and it will become harder to open and close the waterproof parts. Because of this, it could become impossible to open or close the housing or it could cause flooding, so please refrain from using the housing with insufficient grease.

Are there any scratches or cracks in the O-ring?

Check the O-ring to make sure there are no scratches or cracks. If there are, replace the O-ring with a new one immediately. When handling the O-ring, do not use pointed metal objects, which could damage the O-ring. Use of the included O-ring remover is recommended.

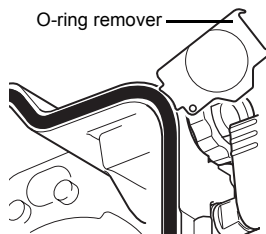

Be careful about dust, sand, and hair

Check the O-ring to make sure that there is no dust, sand, or hair on the O-ring, in the O-ring's grooves, or on the O-ring's contact surfaces. If any of these things are attached, remove them completely. If used as is, these things could cause flooding.

Precautions on Handling the O-ring

Coat with silicone grease

Silicone grease protects the O-ring from chafing. After checking the O-ring to make sure that there are no scratches, dust, or debris, apply a light coating of silicone grease to the entire O-ring with your finger. Applying too much grease will make it easier for dust and debris to adhere to the O-ring, and could cause flooding.



Do not twist the O-ring

When fitting the O-ring into the O-ring groove, insert it straight into the groove; do not bend or twist it.

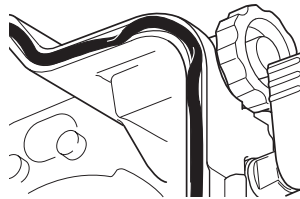

Remove the O-ring for inspection before each use

In principle, the O-ring should be removed before each use so that the O-ring, O-ring groove, and O-ring contact surfaces can be checked. This is because you cannot find any sand or debris that may have gotten into the O-ring groove if the O-ring is not removed. For routine maintenance prior to each use, it is advisable to make sure to remove the O-ring.

Be careful about how you store O-rings

When storing spare O-rings or O-rings that you have removed from the housing, keep them in a cool place out of direct sunlight. Also, when storing O-rings, do not place heavy objects on them or twist them.

O-rings last for one year

Although it depends on how well they are maintained, how often they are used, and how they are stored, O-rings generally last for one year. It is advisable to inspect them before use, and replace them early.

Identification of Parts

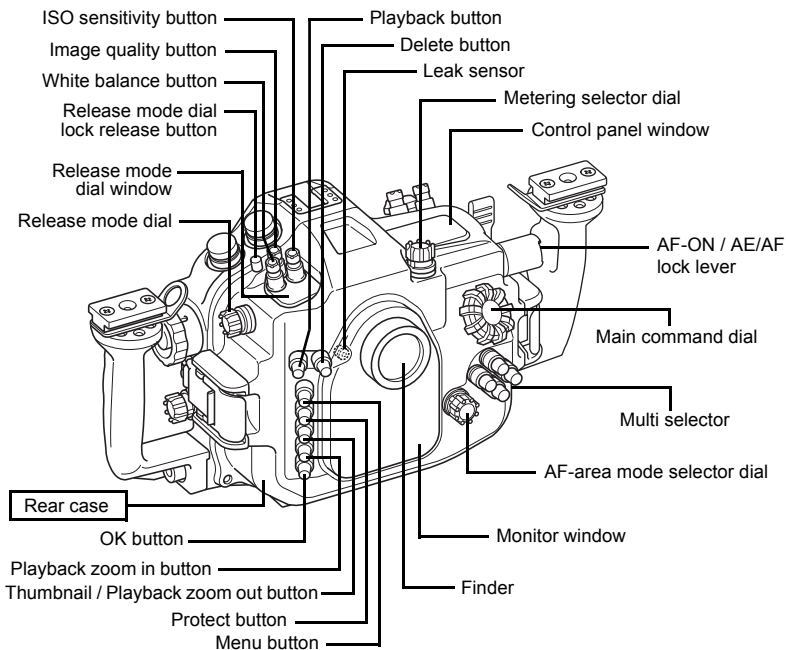
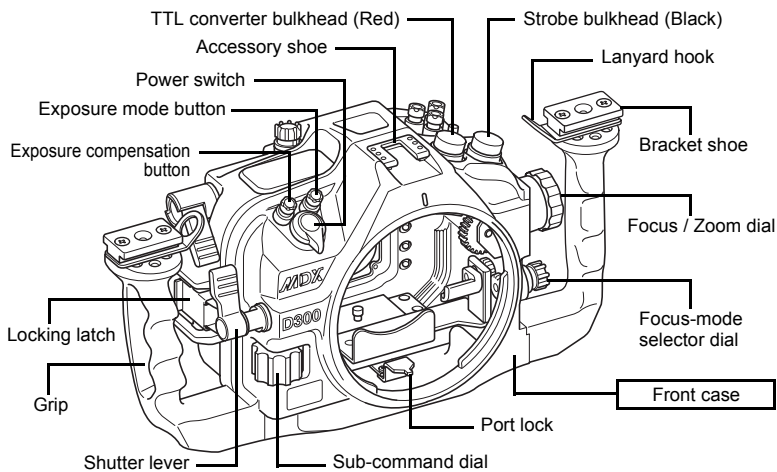

Identification of Parts

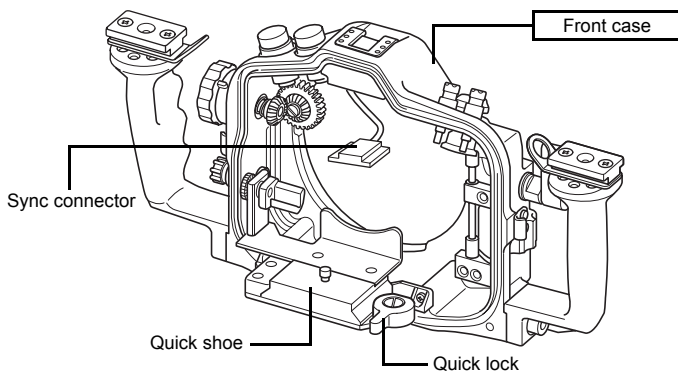

Leak Sensor

The leak sensor lights up in red if water leakage is detected while underwater. If the leak sensor lights up, surface as soon as you safely can and remove the camera from the housing.

CAUTION

If a lot of water leaks in, the atmospheric pressure inside the housing will increase, which is very dangerous. When releasing the locking latches, the rear case could come flying off, so be very careful.

Leak sensor

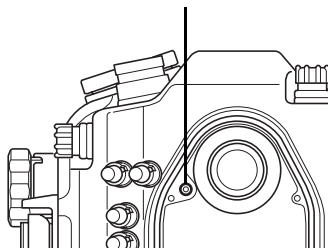

Replacing the leak sensor battery

Instructions for replacing the leak sensor battery set in the rear case.

CAUTION

Use CR2032 batteries.

- 1 Press the round center part firmly and remove the battery
- 2 Insert the battery with the plus side up

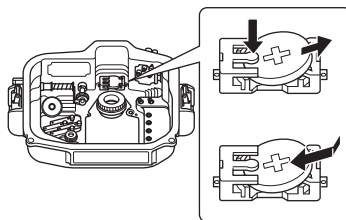

Finder

This model comes equipped with a standard finder (0.66x). The finder is replaceable; if you replace it with an optional finder unit, you can change the finder magnification to match your shooting conditions.

Replacing the finder

- 1 Rotate the finder unit mounted on the rear case in a counterclockwise direction to remove it**

- The screw areas are coated in grease, so be careful not to touch them.

- 2 Rotate the replacement finder unit in a clockwise direction to attach it**

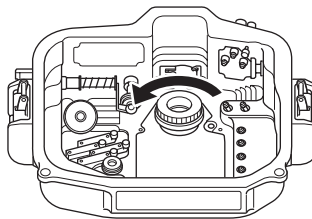

⚠ CAUTION

- Before attaching the finder, check to make sure that there is no dust, dirt, or debris inside it.
- When replacing the finder, do not touch the surface of the finder lens.

Opening and Closing the Housing

Opening and closing the housing is done with the locking latches. Here we will explain how to open and close the locking latches.

Opening the locking latches

- 1 With the surface of the rear case facing up, press and hold the right and left locks (1) and remove the locking latches from the hooks (2)

CAUTION

- When removing the locking latches, be sure to use the tips of your fingers, not your fingernails.
- If you lock the locking latch after it is removed from the hook, it is easier to remove the rear case.

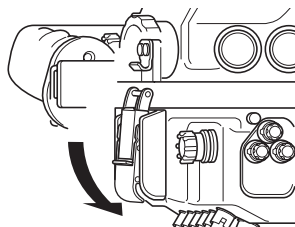
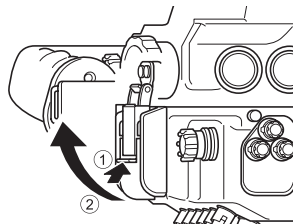

Closing the locking latches

- 1 Align the guide pins of the front case (two places) with the guides on the rear case, and then set the rear case
- 2 Put the right and left locking latches on the hooks, and close the locking latches simultaneously

CAUTION

- Before aligning the rear case and front case, make sure there are no specks of dust, scratches, or deformities on the O-ring and the O-ring contact surfaces.
- Check to make sure that the locking latches are securely locked.

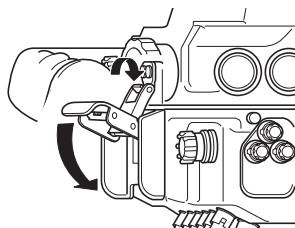

Attaching and Detaching the Port

- 1 Pull the port lock on the bottom of the front case toward **OPEN** until you hear the sound of it clicking into place

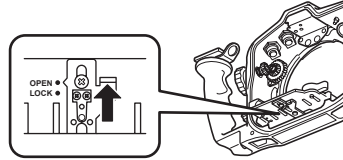

- 2 Align the positioning mark on the front case with the **OPEN** mark on the port, insert the port into the front case, and then rotate the port in a clockwise direction until it stops

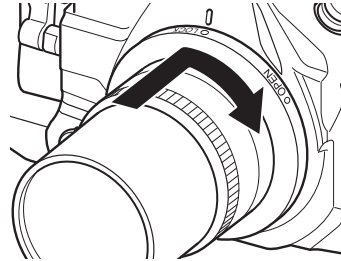

CAUTION

Before attaching the port, make sure there are no specks of dust, scratches, or deformities on the O-ring and the O-ring contact surfaces.

- 3 Make sure that the positioning mark on the front case and the **LOCK** mark on the port are aligned

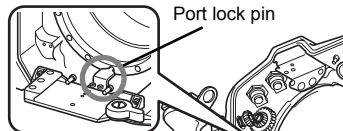

- 4 Push the port lock toward **LOCK** until you hear the sound of it clicking into place

- Make sure that the port lock pin is engaged with the notch in the port.

Detaching the port

- 1 Set the port lock to the **OPEN** position
- 2 Hold the front case firmly and rotate the port in a counterclockwise direction

CAUTION

- Do not attempt to remove the port with the port lock in the LOCK position. Doing so could damage the camera base.
- If using NX-90PRO ports (with 4-digit part numbers and black bayonets) with this model, it is necessary to modify the port's bayonet. NX-90PRO ports with 5-digit part numbers and gray bayonets can be used as is. For details, please contact SEA&SEA or a SEA&SEA authorized dealer.

Mounting the Camera in the Housing

⚠ CAUTION

- Before mounting the camera in the housing, make sure the O-ring is not sticking out of its groove.
- Make sure to remove the eyecup from the camera. If used with the eyecup in place, it could cause flooding.

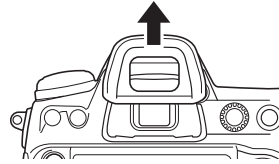

- 1 Rotate the quick lock in the OPEN direction, and then remove the quick shoe from the front case**
- 2 Switch the camera's focus-mode selector to C (continuous-servo AF)**
- 3 With the A groove on the quick shoe aligned with the focus-mode selector, fix the quick shoe on the tripod socket using the included attachment tool**

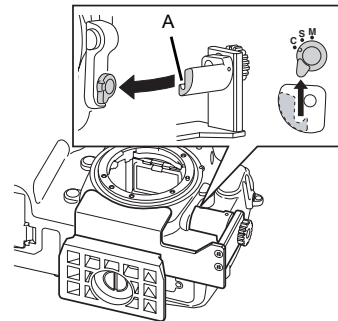
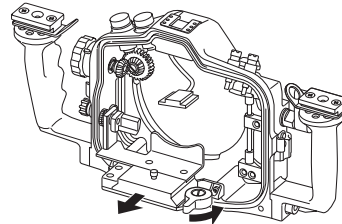

- 4 Attach the lens to the camera**
- 5 Make sure the quick lock is in the OPEN position**

Mounting the Camera in the Housing

6 Slide the camera forward into the front case

- Move the sync connector clear of the front case.
- To make sure that the gear attached to the lens and the gear on the front case do not hit each other, rotate the focus / zoom dial while sliding the camera into place.

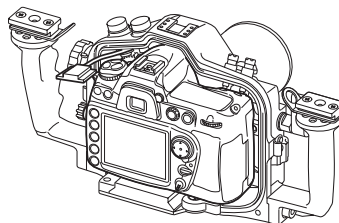

7 Align the quick lock with the LOCK position to fix the camera in place

8 Rotate the power switch on the housing so that it is facing the same way as the power switch on the camera

9 Insert the sync connector into the camera's accessory shoe

⚠ CAUTION

When inserting or removing the sync connector, be sure to hold the connector part. If you push or pull on the cord part, it could damage the sync connector or cause contact failures.

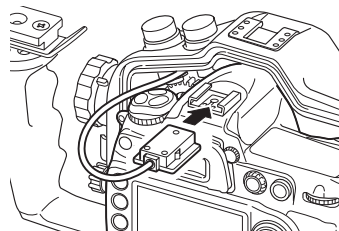

10 Align the guide pins of the front case (two places) with the guides on the rear case, and then set the rear case

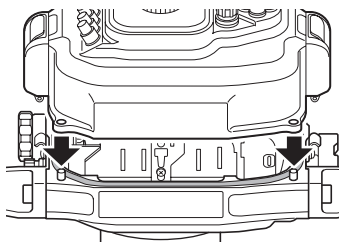

⚠ CAUTION

Before setting the rear case, put the camera's eyelets in the positions shown by the arrows.

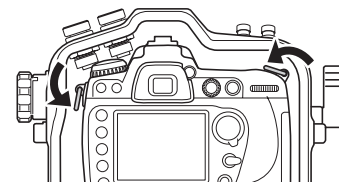

Mounting the Camera in the Housing

11 Close the locking latches

⇒ **See:**

“Opening and Closing the Housing” (P. E-9)

Removing the camera from the housing

- 1** Open the locking latches
- 2** Remove the rear case
- 3** Remove the sync connector from the camera’s accessory shoe
- 4** Set the quick lock to the **OPEN** position
- 5** Slide the camera toward you as you remove the front case

Connecting the Strobe

This model comes equipped with a strobe bulkhead (black: ①) and a TTL converter bulkhead (red: ②).

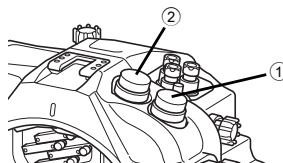

⚠ CAUTION

Make sure never to connect the YS series strobe sync cord to the bulkhead for TTL converter (red: ②). This may damage the pins on the bulkhead connector. Likewise, make sure never to connect the TTL converter's camera connection cable to the strobe bulkhead (black: ①). This may damage the pins on the bulkhead connector.

1 Remove the housing's bulkhead connector cap

2 Make sure there are no scratches or debris on the O-ring of the sync cord being connected

3 Align the round mark on the sync cord (or the notch of the tip) and the round mark on the strobe bulkhead (or the convex part on the inside), and then push it straight in

4 Align the B part of the sync cord with the screws of the strobe bulkhead, and then rotate it until it stops

5 Rotate the C part of the sync cord until it stops

- Tighten it securely.
- When removing the sync cord, loosen C first, then B, and then pull the sync cord straight out holding onto A. Do not pull on the cord part.

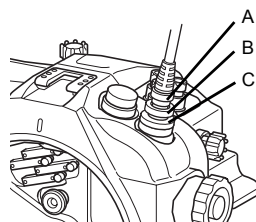
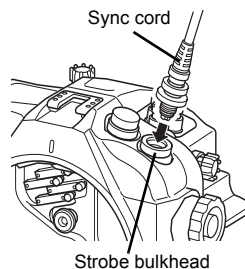

⚠ CAUTION

- After use underwater, make sure to prevent water droplets from dripping into the bulkhead connector by wiping moisture away from the bulkhead connector and then turning the housing upside down and extracting the sync cord. In the event that water droplets do drip into the connector, promptly wipe away all moisture.
- If you use incompatible strobes, not only might they not work correctly, but they may also cause the camera and the strobe to malfunction.

External Controls

Power switch

By rotating the knob as shown, you can turn the power ON/OFF and operate the illumination switch.

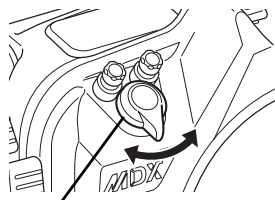

Power switch

Release mode dial lock release button, Release mode dial

Rotate the release mode dial while pressing the release mode dial lock release button.

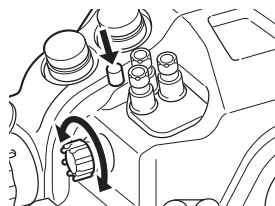

Exposure compensation button, Exposure mode button, Image quality button, ISO sensitivity button, White balance button

While pressing the buttons, rotate the main command dial or sub-command dial to make operation settings. By rotating the buttons while pressing them in, you can fix them in the pressed-in state.

Focus / Zoom dial

When shooting with a focus / zoom gear:

Pull the focus / zoom dial out and rotate it so that the convex part of the dial is set in the deep groove on the spacer.

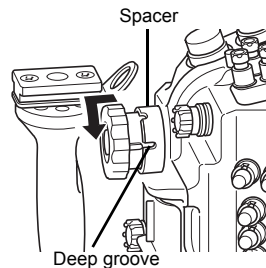

External Controls

When shooting without a focus / zoom gear

Pull the focus / zoom dial out and rotate it so that the convex part of the dial is set in the shallow groove on the spacer.

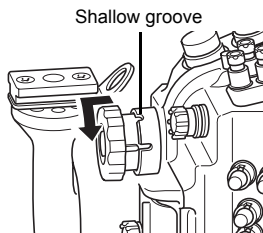

CAUTION

- The focus / zoom dial cannot be used if there is no gear mounted on the lens.
- When using a zoom gear, you cannot shoot with manual focus.
- If you will be shooting autofocus shots with the focus gear mounted on the lens, make sure to use the shallow groove. If you set it to the deep groove, it could damage the lens.

AF-ON / AE/AF lock lever

When shipped from the factory, the lever is set to the position for operating the AE/AF lock button. To operate the AF-ON button, follow the procedures below to change the position of the lever.

- 1 Pull the lever in the direction of the arrow and keep it there.

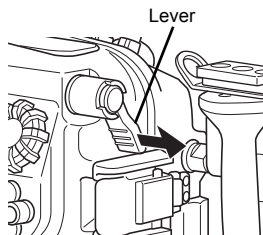

- 2 Rotate the collar in the direction of the arrow.

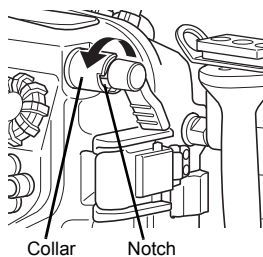

External Controls

- 3 Set the lever in the notch in the collar.

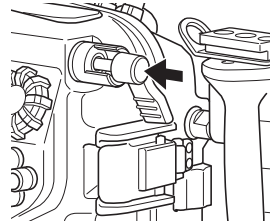

Main command dial, Metering selector dial, AF-area mode selector dial

Rotate the dials while pressing them in to operate them.

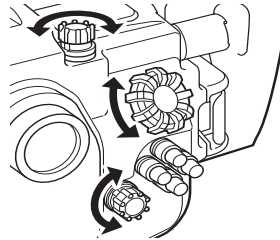

Other controls

Please read the instruction manual for the camera.

Maintenance and Storage

CAUTION

- Never use chemicals, cosmetics, any petroleum solvents such as paint thinner, or neutral detergent on the product. They may deform and damage the product.
- After each use in salt water, make sure it's watertight, then soak it sufficiently in fresh water.
- Insufficient soaking causes damage by salt to the product. Salty residue may be left on the product where it will crystallize as it evaporates. Crystallized salt is hard to dissolve and difficult to be removed once formed, and it will result in water leakage.
- After rinsing, dry the product well with a soft dry cloth, then let the product dry in the shade, out of direct sunlight.
- Do not dry the product by heating (using a hair dryer, for example). Heating can deform and damage the product.
- If you will not use the product for an extended period of time, store it away from high temperatures, high humidity, direct sunlight, or extreme cold.
- Do not store the product with naphthalene or camphor mothballs, or in locations such as a laboratory where chemicals are used. This environment can cause mold, rust, corrosion or malfunction.
- Always remove the camera from the housing after use. Thoroughly wipe off water before opening the housing and avoid any water drops inside the housing.
- After using the product, maintain the O-rings before storing. Examine the O-rings before and after each dive. We recommend early exchange of the O-rings, at least once a year.
- Every two years we recommend a complete overhaul of O-rings regardless of the frequency in use, for the best performance of the product.

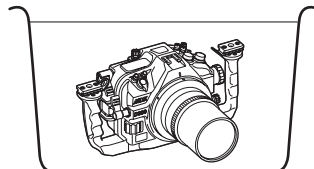

Specifications

Compatible camera	Nikon D300
Controls	Power switch, Shutter lever, Exposure compensation button, Exposure mode button, Sub-command dial, Focus / Zoom dial, Focus-mode selector dial, White balance button, Image quality button, ISO sensitivity button, Release mode dial lock release button, Release mode dial, Metering selector dial, Main command dial, AF-ON / AE/AF lock lever, Multi selector, AF-area mode selector dial, Delete button, Playback button, Menu button, Thumbnail / Playback zoom out button, Playback zoom in button, Protect button, OK button
Construction	Body: Corrosion-resistant aluminum alloy Grip: Corrosion-resistant die-cast aluminum
Depth rating	60 m (200 feet)
Dimensions	Approx. 339 (W) × 169 (H) × 143 (D) mm (13.3 × 6.7 × 5.6 inches)
Weight	2500 g (5.5 lbs.) (housing only)
Accessories	Silicone grease, O-ring remover, Attachment tool, Hexagonal wrench, Quick shoe, Housing body cap, CR2032 lithium battery (for leak sensor, preinstalled into battery compartment), Instruction manual (this manual), O-ring maintenance manual

* The specifications and appearance are subject to change without notice.

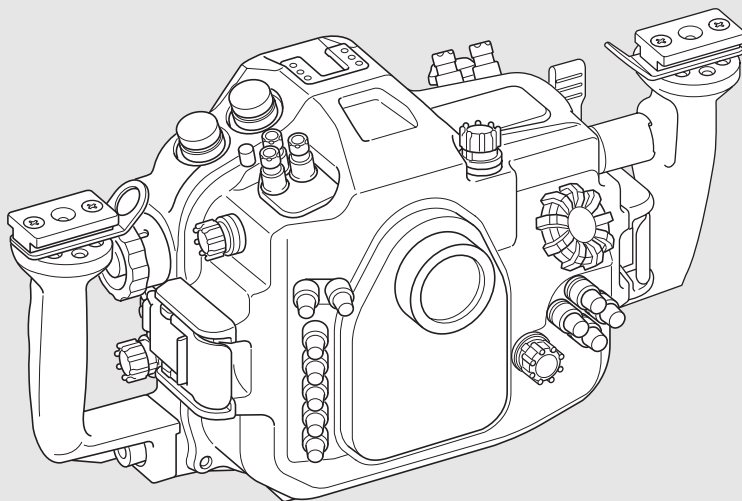

SEA&SEA

シーアンドシー・サンパック株式会社

〒332-0016 埼玉県川口市幸町3-2-20
TEL.048-256-2251

カスタマーサービスセンター

TEL.048-255-8512
<http://www.seaandsea.co.jp>

SEA&SEA SUNPAK Co., Ltd.

3-2-20, Saiwai-cho, Kawaguchi-shi,
Saitama, Japan 332-0016
TEL. +81-48-256-2251

World Customer Service Center

TEL. +81-48-255-8512
<http://www.seaandsea.jp>

0742-Z-01